



INSTALLATION MANUAL
VENGEANCE REAR BUMPER
PRODUCT NUMBER: E6451
APPLICATION: 2024 FORD RANGER RAPTOR



IMPORTANT SAFETY GUIDE | Your safety and the safety of others is very important.

In order to help you make informed decisions about safety, we have provided the following warnings, safety precautions, installation instructions, and other important information to alert you to potential hazards that could hurt you or others.

Please do a job safety analysis before each task to identify potential hazards for your situation and remove/protect against them. Use own good judgment and take your time.

Check packaged materials immediately upon arrival to ensure that all listed parts are included and undamaged.

Read and understand all warnings, safety precautions, and instructions before installing this product.

SENSORS FIELD OF VIEW MAY BE ALTERED WITH USE OF THE REPLACEMENT BUMPER.

WARNINGS

- Failure to observe the following warnings and instructions provided in this manual could lead to severe injury and/or death.
- For professional installation only. Careless installation and/or operation can result in serious injury, death, and/or equipment damage. All liability for installation and use rests with the user or consumer.
- Fab Fours, Inc. only approves installing this product according to these written instructions with the hardware provided. Failure to install according to these instructions will invalidate the warranty. This includes, but is not limited to, using alternative installation methods, hardware, or materials.
- This product is for off road use only.

SAFETY PRECAUTIONS

- Always remove jewelry and wear eye protection.
- Always use extreme caution when jacking up a vehicle for work. Set emergency brake and use tire blocks. Locate and use the vehicle manufacturers designated lifting points. Use jack stands.
- Always use appropriate and adequate care in lifting components into place.
- Always ensure components will remain secure during installation and operation.
- Always wear safety glasses when installing this kit. A drilling operation will cause flying metal chips. Flying chips can cause serious eye injury.
- Always use extreme caution when drilling a vehicle. Always disconnect power before welding. Thoroughly inspect the area to be drilled (on both sides of material when possible) prior to drilling, and relocate any objects that may be damaged.
- Always use extreme caution when welding a vehicle. Thoroughly inspect the area to be welded (on both sides of material when possible) prior to welding, and relocate any objects that may be a fire hazard. When welding in a cab, make sure the interior surfaces are covered (e.g., welding blanket) and a fire extinguisher is at hand.
- Always use extreme caution when cutting and trimming during fitting.
- Always tighten all nuts and bolts securely per installation instructions.
- Always route electrical cables carefully. Avoid moving parts, components that become hot, and rough or sharp edges.
- Always insulate and protect all exposed wiring and electrical terminals.
- Perform regular inspections and maintenance on mounts and hardware.

TABLE OF CONTENTS

- 2 SAFETY / DISCLAIMER
- 3 TABLE OF CONTENTS
- 4 A MESSAGE FROM THE OWNER
- 5 GETTING STARTED
- 6 PROVIDED MATERIAL
- 8 INSTALLATION
- 16 CONTACT

A MESSAGE FROM THE OWNER



Fab Fours' was born out of a passion for customizing vehicles and a love of the outdoors. Our engineering team uses the latest 3D design software to turn new product ideas into reality. In our factory, designs come to life with the combination of cutting edge technology for metal cutting and forming and an American workforce that puts its' heart and pride into every product.

From design and manufacturing, to quality and delivery, Fab Fours' mission is to be the market leader for steel truck and jeep accessories. We make sure a quality product is delivered on time, more than expected, better than expected to our customers.

Enjoy your new Fab Fours product. Welcome to the family!

Greg Higgs

FOUNDER, FAB FOURS

GETTING STARTED

Before you begin the installation process of your new Fab Fours product, we suggest laying out all materials and parts on a pad or protective surface.

Failure to fully account for all components before beginning installation may leave vehicle immobile until part is acquired. Refer to the next pages as an inventory check.

PROVIDED MATERIALS



23309 - BUMPER SHELL



23325 - TAG LIGHT HOLD DOWN QTY: 2

61632 EPOXY QTY:2

REQUIRED TOOLS

- BODY PRY TOOL
- T30 TORX BIT
- 13MM SOCKET WRENCH
- 18MM SOCKET WRENCH
- SOCKET EXTENSION

ASSISTANCE

We recommend two people perform the installation as items are heavy and may need to be held in place while installing.

ORGANIZATION

Disassemble the vehicle where you can catalog and store everything. We suggest labeling and bagging all the OEM bolts when removing from the vehicle. Failure to keep track of parts could lead to an inability to properly reinstall components.



HARDWARE KIT | 50491-HW

IDENTIFICATION NUMBER	COMPONENT DESCRIPTION	QTY
50491-HW	M12-1.75 X 35MM, HEX CAP SCREW, YELLOW-ZINC, CLASS 8.8	2
50491-HW	M12, FLAT WASHER, YELLOW-ZINC	2
50491-HW	#10-24, CLIP ON BARREL NUT	4
50491-HW	#10-24 X 3/4", BUTTON SOCKET CAP SCREW, SS	4
50491-HW	#10, FLAT WASHER, SS	4
50491-HW	LICENSE PLATE NUT	2

DISASSEMBLY & INSTALLATION

1. Using a T15 Torx bit, remove the screw in the bottom of the two (2) panels on either side of the hitch receiver. Then, pull on the panels to release the clips and remove the panels. (Figure 1-2)



Figure 1

2. Using a 13mm socket wrench, remove the four (4) nuts across the bottom of the OE bumper. (Figure 2)



Figure 2

3. Using a 13mm socket wrench with a long extension, remove the two (2) nuts behind the OE bumper. (Figure 3)



Figure 3

4. Using a 13mm socket wrench with a long extension, remove the nut on either side under the OE bumper above each tow hook. (Figure 4)

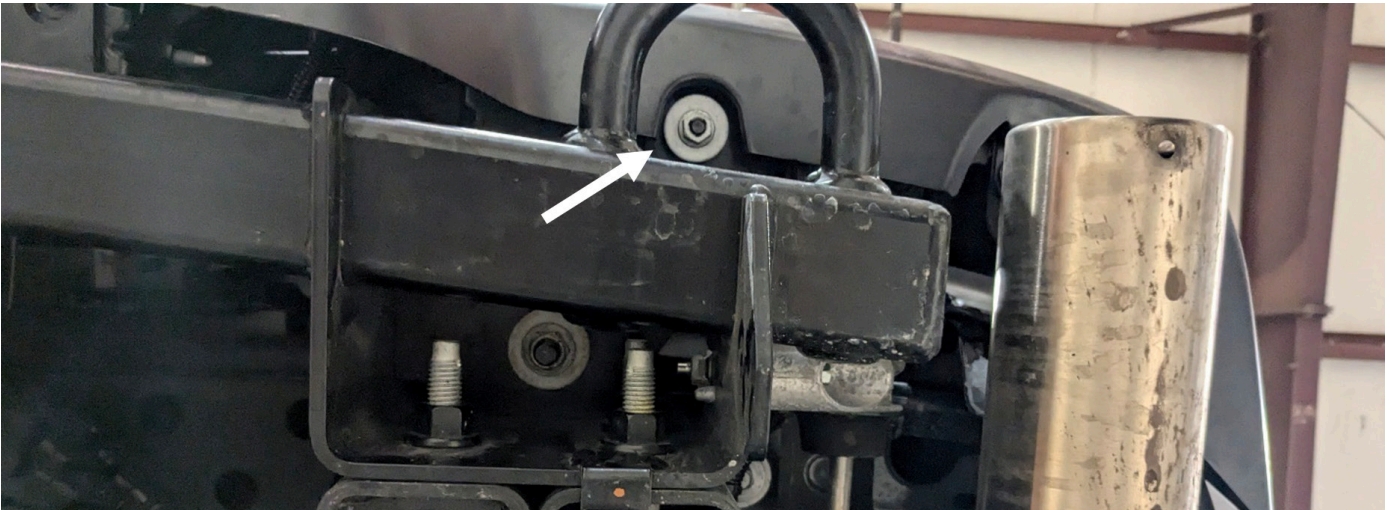

Figure 4

-
5. Using an 18mm socket wrench with a long extension, remove the nut on either side under the OE bumper inside of the mounting bracket. (Figure 5)



Figure 5

6. Disconnect the wiring harness inside of the driver's side frame rail. The bumper can now be removed from the vehicle. (Figure 6)

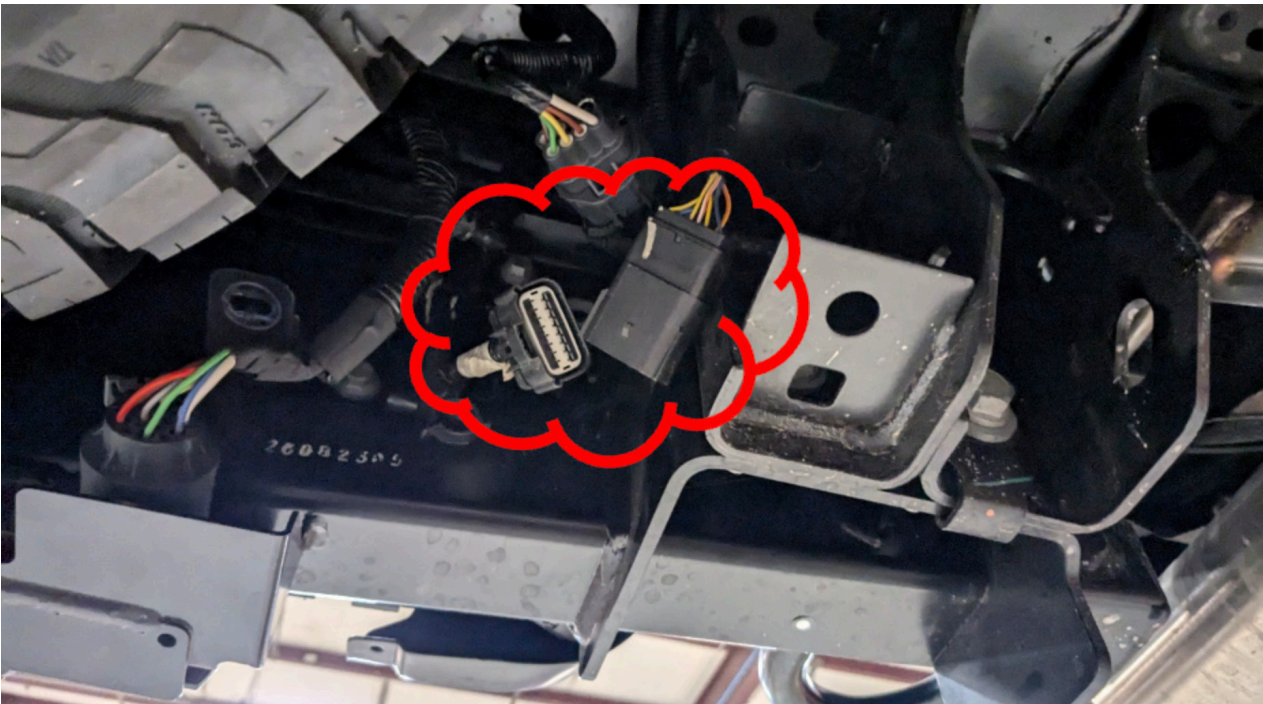

Figure 6

7. Using a panel pry tool, release all the wiring harness retainers from the inside of the bumper. (Fig 7)



Figure 7

8. Disconnect the OE tag light wiring connector. (Figure 8)

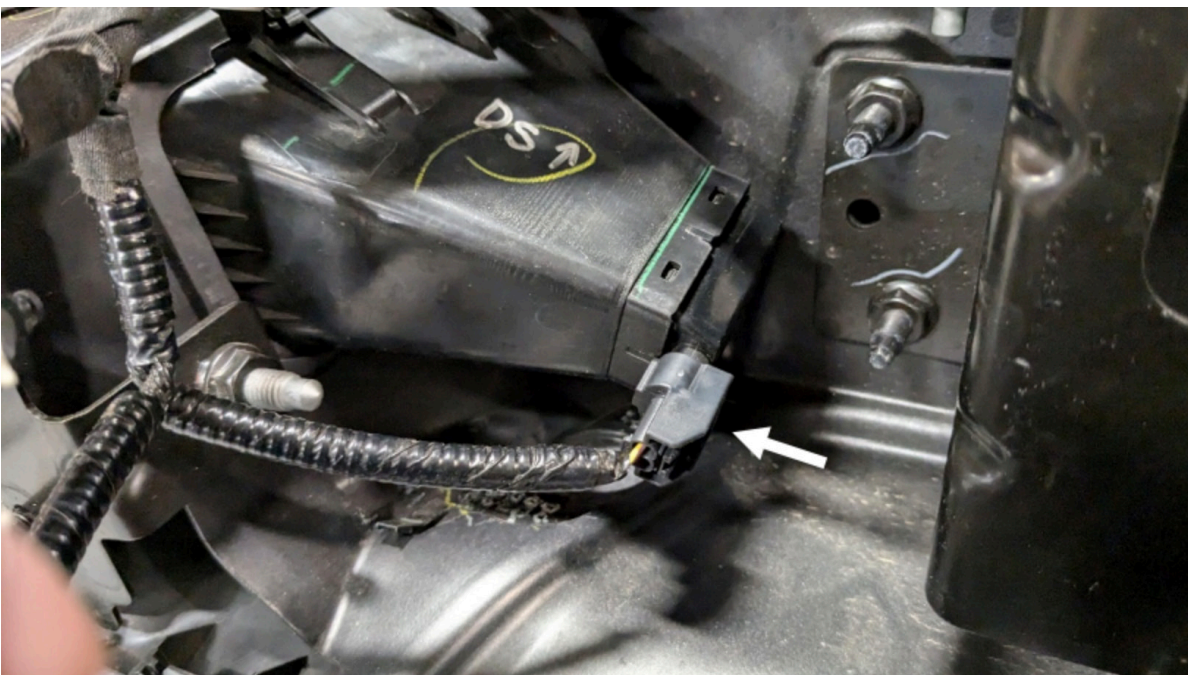

Figure 8

9. Mark the parking sensor's location in the factory bumper to aid reassembly. Then, spread the housings holding the parking sensor in the bumper to remove the sensors from the bumper. (Figures 9-10)



Figure 9



Figure 10

10. With the sensors removed from their housings, squeeze the housings to push them out of the bumper shell. (Figure 11-12)



Figure 11



Figure 12

11. Using a panel pry tool, carefully remove the tag lights from their housing by spreading the housing to release the tabs. (Figure 13-14)



Figure 13



Figure 14

12. Reinstall the OEM tag lights into the Fab Fours bumper using the two (2) provided light brackets and four (4) #10 hex head cap screws, flat washers and barrel nuts. Clip the barrel nuts onto the tabs welded into the bumper. (Figures 15)

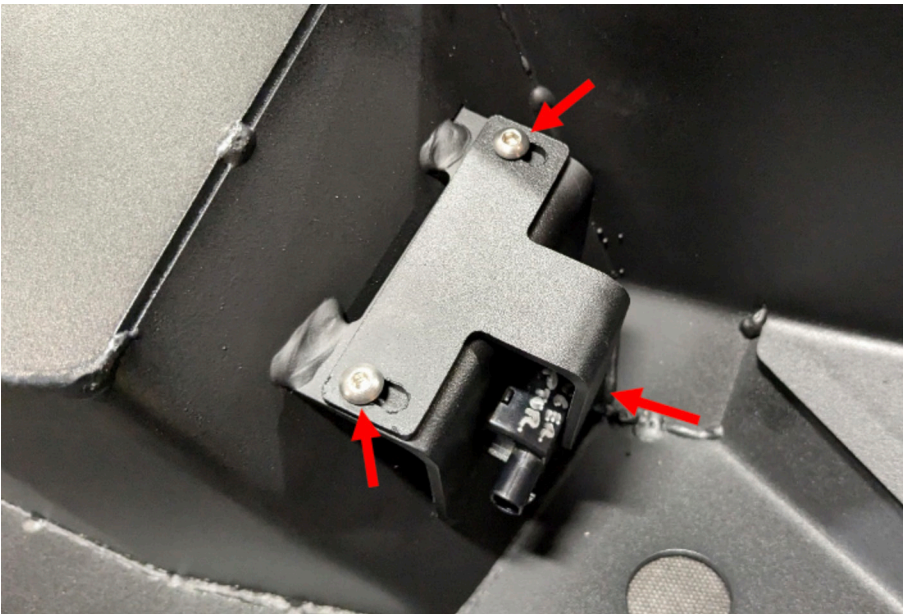

Figure 15

-
13. Reinstall the parking sensors and harness into the Fab Fours bumper in the same location and orientation from which they were removed. Use the provided epoxy to attach the sensor housings to the bumper shell. (Figures 16)

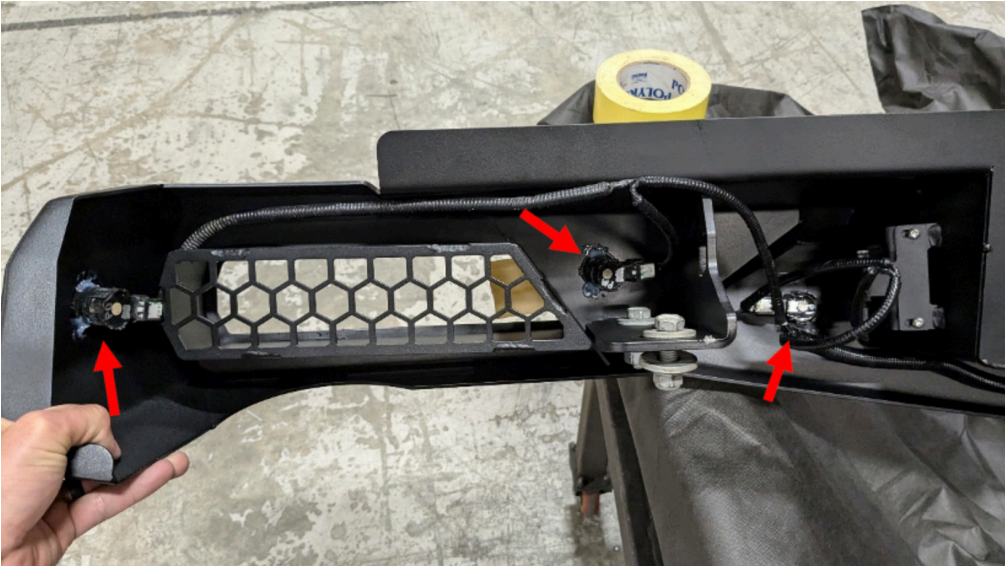

Figure 16

14. Loosely install the two (2) provided M14 Hex head cap screws, flat washers and OEM nuts into the slots of the bumper mounts. (Figures 17)

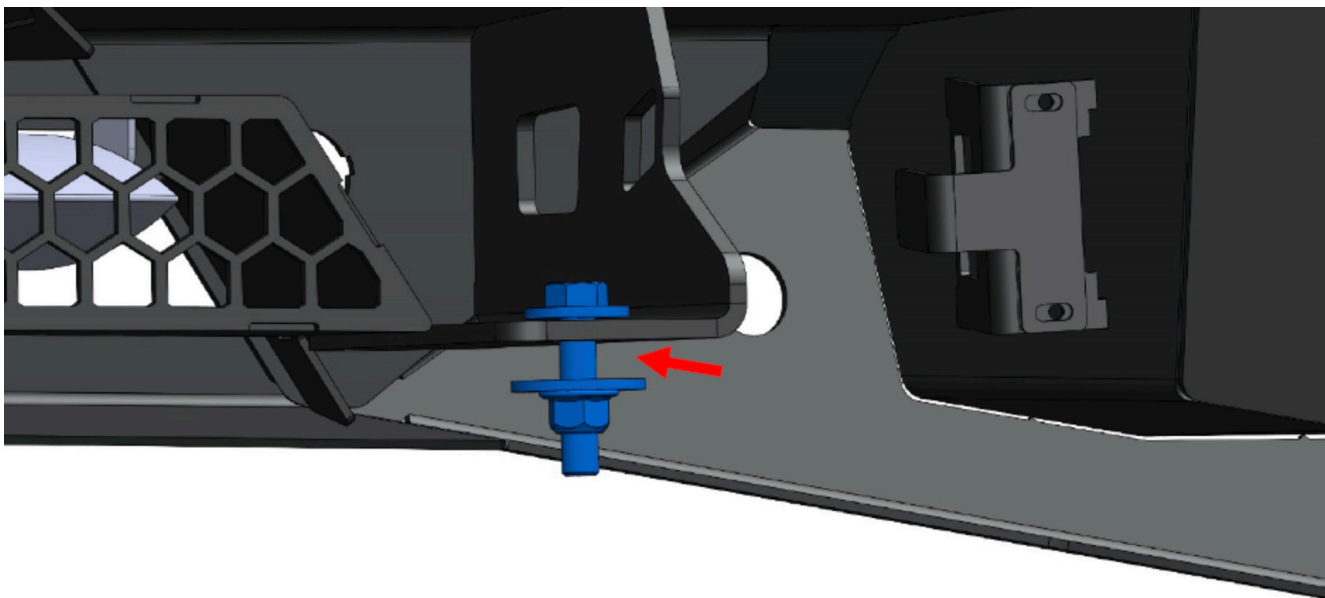

Figure 17

15. With assistance, hold the bumper up to the vehicle and align it left to right and in and out as desired. Use an 18mm socket and combination wrench to tighten the two (2) bolts. (Figures 18)

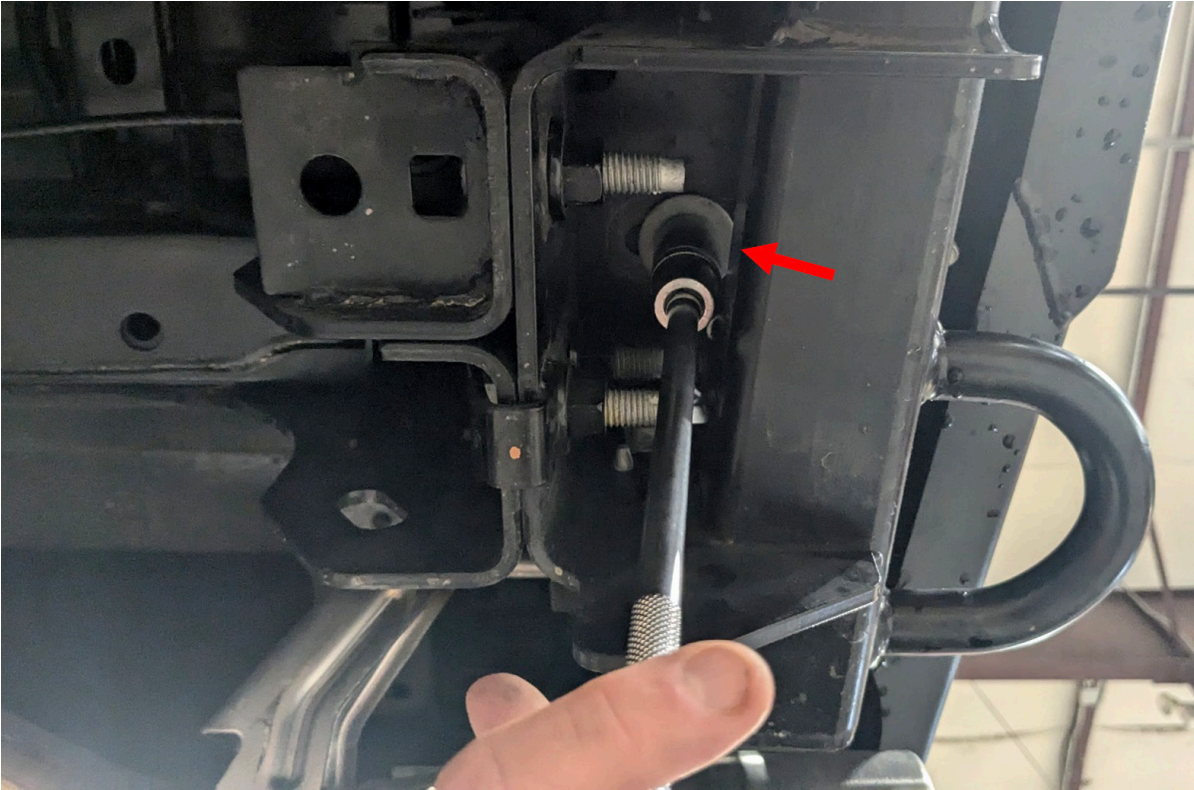

Figure 18

INSTALLATION COMPLETE

CONTACT INFORMATION

**FAB FOURS INC.
2213 INDUSTRIAL PARK ROAD
LANCASTER, SC 29720**

PHONE: (866) 385-1905

FAX: 970-385-1914

EMAIL: SUPPORT@FABFOURS.COM

FABFOURS.COM



**“IF YOU’RE LOOKING FOR MORE OF THE SAME,
THEN YOU’VE COME TO THE WRONG PLACE.”**

- GREG HIGGS

